

**VALPARAISO UNIVERSITY**  
**ELECTRICAL AND COMPUTER ENGINEERING DEPARTMENT**

**ECE 221**

**Final Examination**

**Fall 2002**

**Name:** \_\_\_\_\_

**Honor Code Pledge:** \_\_\_\_\_

\_\_\_\_\_  
\_\_\_\_\_

**Signature:** \_\_\_\_\_

This is an open-book, closed-notes examination to be performed by each student individually. Write your name on the line above before you start the exam, and then write out and sign the honor code after you have completed the exam. For each question show the development of your solutions and then place your final answer in the space provided.

Problem 1	/10
Problem 2	/15
Problem 3	/30
Problem 4	/20
Problem 5	/25
Total	/100

**Question 2: State Reduction (25 Points)**

A Moore-type state transition table is shown at the left below. Reduce the table to a minimum number of states and put your results in the empty table on the right below. Retain the states that have the alphabetically lesser letters. That is, if A and C are equivalent, retain A and eliminate C. Your reduced table should have a number of empty rows. Use the implication chart at the bottom of the page to assist in your reduction.

Present State	Next State		Output Z
	X=0	X=1	
A	B	C	1
B	D	F	1
C	F	E	0
D	B	G	1
E	F	C	0
F	E	D	0
G	F	G	0

Present State	Next State		Output Z
	X=0	X=1	

B						
C						
D						
E						
F						
G						
	A	B	C	D	E	F

**Question 3: Circuit Implementations (30 points)**

Given the following SOP function:

$$F(A, B, C, D) = ABCD + A\bar{C}D + A\bar{B}\bar{D} + A\bar{C}\bar{D} + \bar{A}C + \bar{A}\bar{B}\bar{C}\bar{D}$$

Assuming A is the MSB, create the following minimized implementations of the function F.

a) (5 points) **PLA Implementation:** (Make the proper connections on the circuit below and label the product outputs in the boxes):

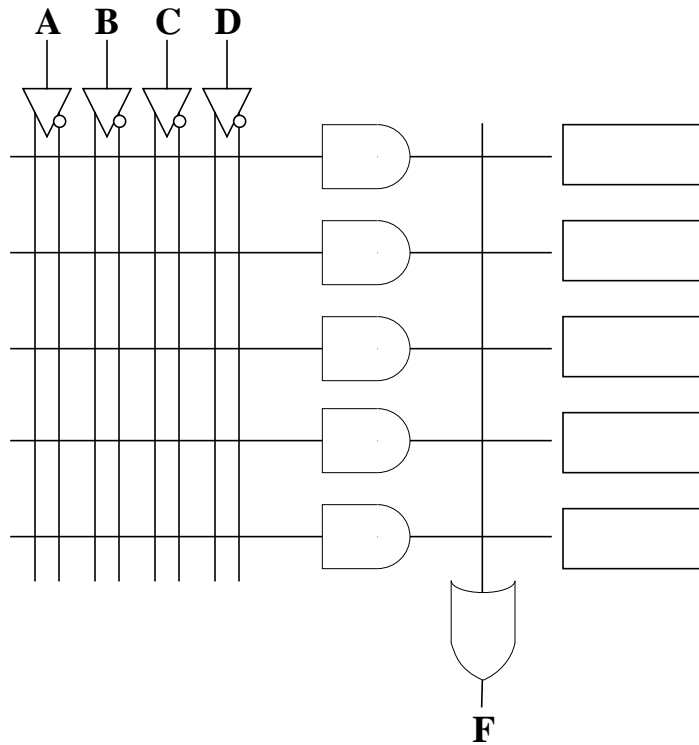

b) (10 points) **2:1 Multiplexer Implementation:** Add the input values to the multiplexers below. Minimize the number of extra gates used and assume the variables (A,B,C,D) are available only in uncomplemented form.

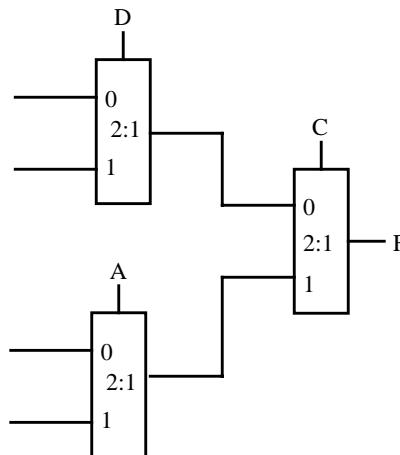

**Question 3: Circuit Implementations (cont.)**

c) (5 points) **2-input Gate Implementation:** Use only 2-input AND, OR, NAND, NOR, XOR, or XNOR gates to implement F. Assume complemented inputs ARE NOT available.

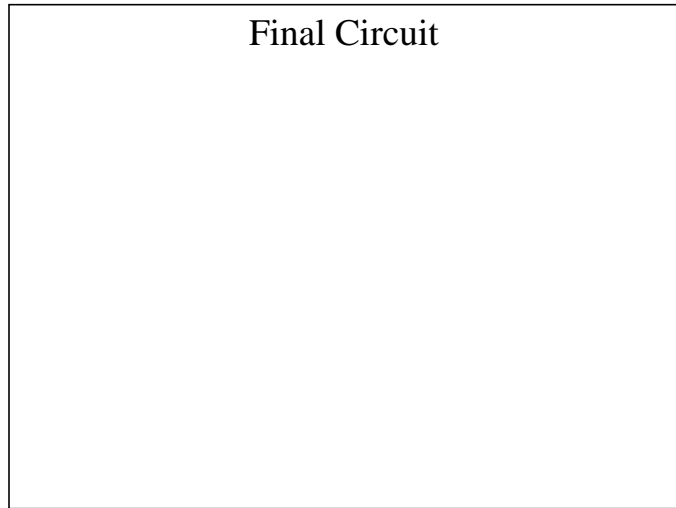

**Question 4: Mealy and Moore State Diagrams (20 points)**

a) (10 points) Develop the minimized state diagram for a **Mealy** non-resetting sequence detector whose single output **Z** is asserted-1 active when after the occurrence of 000 or 001 for the input **X**. An example of an input/output sequence for this device is:

Input    X = 000100101000000101100010  
Output   Z = 001100100001111100000110

b) (10 points) Develop the minimized state diagram for a **Moore** non-resetting sequence detector whose single output **Z** is asserted-1 active after occurrence of the sequence 110 or 011 for the input **X**. An example of an input/output sequence for this device is:

Input    X = 011111011001110110100  
Output   Z = 000100010110010101100

**Question 5: Sequential Circuit Design (25 Points)**

You are to design a vending machine controller that takes as input either a nickel, dime or quarter and outputs a product when a total of 20 cents or more is entered (your controller will not give any change). The controller will be implemented as a resetting MEALY machine. Since the controller has four possible inputs during each state, we will assume the following input encoding for the two inputs,  $IN_1$  and  $IN_0$ :

No change entered = 00  
 Nickel entered = 01  
 Dime entered = 10  
 Quarter entered = 11

The output is asserted-1, meaning that when the total is reached, the output is set to 1. This triggers a mechanical latch and one item is given to the user. The controller then goes to the reset state and waits for more money.

a) (5 points) **Understand the Problem:**

Finish the output sequence given the following input sequence where “H” is no change entered, “N” is nickel entered, “D” is dime entered and “Q” is quarter entered.

Input = N D N D H Q Q H H D D Q N N N H H D H  
 Output = -

b) (10 points) **State Transition Diagram:** Complete the state diagram by adding the appropriate transitions given the description of the states listed below.

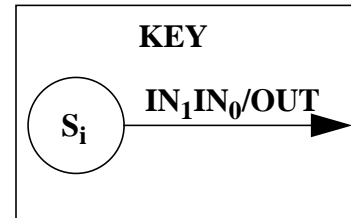
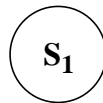

- S0: no money entered
- S1: 5 cents entered
- S2: 10 cents entered
- S3: 15 cents entered

**Question 5: Sequential Circuit Design (cont.)**

c) (5 points) **State Transition Table:** Fill in the state transition table assuming the following state encoding: S0 = 00, S1 = 01, S2 = 10, and S3 = 11.

Current State			Input		Next State		Output
State Name	Qa	Qb	IN <sub>1</sub>	IN <sub>0</sub>	Qa <sup>+</sup>	Qb <sup>+</sup>	OUT
S0	0	0	0	0			
	0	0	0	1			
	0	0	1	0			
	0	0	1	1			
S1	0	1	0	0			
	0	1	0	1			
	0	1	1	0			
	0	1	1	1			
S2	1	0	0	0			
	1	0	0	1			
	1	0	1	0			
	1	0	1	1			
S3	1	1	0	0			
	1	1	0	1			
	1	1	1	0			
	1	1	1	1			

d) (5 points) **Flip Flop Implementation:** Assuming the controller will be implemented with D flip flops and using your state transition table, what are the MINIMIZED boolean expressions for the next state logic?

**Da** = \_\_\_\_\_

**Db** = \_\_\_\_\_